

Réf. moteur	L ₁ =	Nbre d'étages	L ₂ =
MA 78-50	129,0 mm	1	73,1 mm
MA 78-100	169,0 mm	2	87,3 mm
		3	101,4 mm

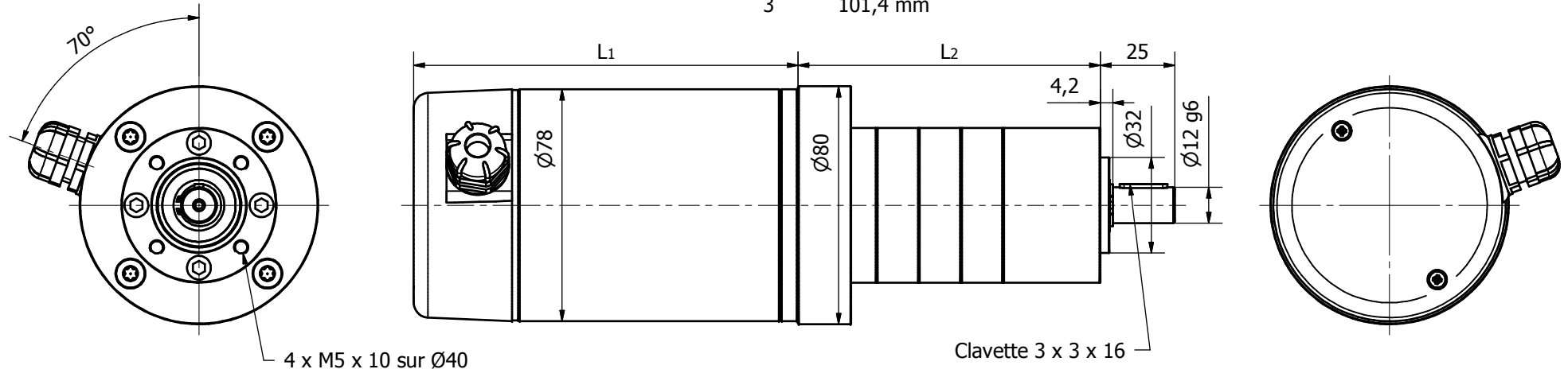

Motoréducteur PA 78-52