

MA 42-40 MOTOR

DESCRIPTION

- Permanent magnet motor.
- Rotation direction CW seen from shaft end, the reverse may be obtained by reversing the electrical connection.
- Rotation on 2 sleeve bearings made of sintered bronze or 1 or 2 ball bearings as an option.
- Electrical connection on 2 tabs of 4.8 x 0.5 mm.
- The 2 brushes are removable for possible replacement.
- Sealing Class: IP50.
- Insulation Class: B.
- Brush life time up to 3000 h depending use cycles.

OPTIONS

- Any other input DC voltage is possible up to 240VDC.
- Any other rotation speed between 1000 and 8000 RPM is possible on request.
- Possibility of 1 or 2 ball bearings.
- Possibility of other flange with fixing extensions for example.
- Possibility of shaft end dedication, in line to your need.
- Possibility to adapt a second output shaft on the opposite side of regular output shaft.
- Possibility to fit a tachometer.
- Possibility to fit a parallel gear reducer or planetary gear reducer (refer following pages).

2D PLAN

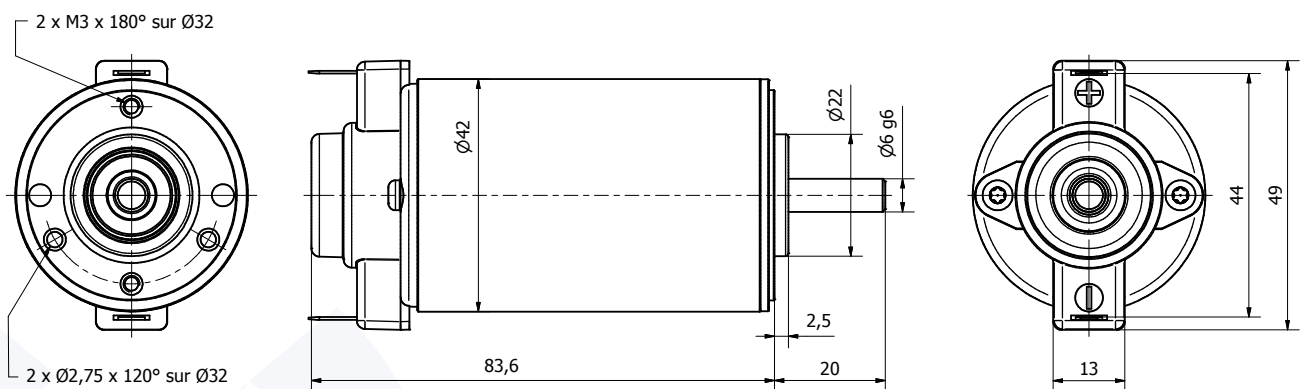

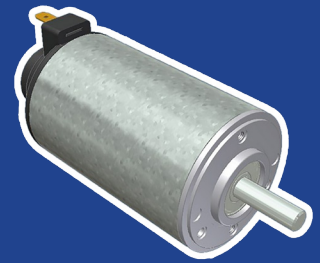

MA 42-40 MOTOR

CHARACTERISTICS



Part number	MA 42-40 001	MA 42-40 002	MA 42-40 003	MA 42-40 004	MA 42-40 005	MA 42-40 006
Input voltage (VDC)	12	24	48	12	24	48
No load rotation speed (RPM)	3900	4000	4000	2900	3000	2800
No load amperage (A)	1,00	0,55	0,27	0,4	0,2	0,1
Nominal rotation speed (RPM)	3025	3100	3100	2300	2400	2250
Nominal torque (N.cm)	6,9	7,4	7,6	4,8	4,5	4,4
Nominal output wattage (W)	22	24	25	12	11	10
Nominal amperage (A)	3,5	1,9	0,9	1,6	0,8	0,4
Nominal input wattage (W)	42	46	44	19	19	18
Nominal efficiency (%)	53	53	56	61	59	57
Locked rotor torque (N.cm)	31	33	34	23	22	22
Locked rotor amperage (A)	12	6,6	3,2	6,0	3,1	1,5
Rotor inertia (g.cm ²)	120	118	117	120	118	117
Max. weight (kg)	0,4	0,4	0,4	0,4	0,4	0,4

PERFORMANCES

